



Inverter Generator Operator's Manual



This generator is certified in accordance with CSA (Canadian Standards Association) standard C22.2 No. 100-04 (motors and generators) and rated in accordance with PGMA (Portable Generator Manufacturers' Association) standard PGMA G200 (Standard for Testing and Validating Performance of Portable Generators).

BRIGGS & STRATTON POWER PRODUCTS GROUP, LLC
MILWAUKEE, WISCONSIN, U.S.A.

Manual No. 80006389 Revision -

Safe Operation Checklist

Safe operation of the portable generator requires the completion of the following tasks:

Carbon Monoxide (CO) Alarm

- Carbon monoxide (CO) alarm(s) in working order.

Smoke Alarm

- Smoke alarm(s) in working order.

Generator Location

- Generator placed in a Carbon Monoxide (CO) safe zone. See *Generator Location to reduce the Risk of Carbon Monoxide Poisoning*.
- Generator placed in a fire safe zone. See *Generator Location to reduce the Risk of Fire*.
- Generator located on flat and level surface.

Oil and Fuel

- Engine has proper oil level. See *Add Engine Oil*.
- Fuel tank filled at or below baffle. See *Add Fuel*.
- Inspect fuel lines, tank, cap and fittings each time before using generator. DO NOT use if fuel leak or damage is found.

Electrical

- Electrical cords are rated for intended loads. See *Cord Sets and Receptacles*.
- Electrical cords do not run through doorways, windows, holes in ceilings, walls or floors.
- Inspect electrical cords thoroughly before each use. DO NOT use if damaged.
- All labeled electrical cord safeties are understood and being followed.

Operation

- Start engine. See *Starting the Engine*.

Not for
Reproduction



Table of Contents

Safe Operation Checklist	3
Operator Safety	5
Safety Labels	5
Equipment Description	7
Important Safety Information	7
Assembly	10
Unpack Generator	10
Add Engine Oil	10
Add Fuel	10
Grounding Fastener	11
Portable Generator Location	11
Features and Controls	14
Cord Sets and Receptacles	15
STATSTATION™	16
Operation	17
Starting the Engine	17
Connecting Electrical Loads	18
Parallel Operation	18
Stopping the Engine	19
POWERSMART Mode	19
Charging a Battery	19
Don't Overload Generator	20
Maintenance	21
Maintenance Schedule	21
Generator Maintenance	21
Engine Maintenance	22
Storage	25
Troubleshooting	26
Wiring Diagram	27
Warranties	28
Generator Owner Warranty	28
Specifications	32
Product Specifications	32
Common Service Parts	32

Operator Safety

Safety Labels

The generator safety labels shown below and on the next page are placed on your portable generator to draw attention to potential safety hazards.

⚠ DANGER		⚠ DANGER	
<p>Using a generator indoors CAN KILL YOU IN MINUTES. Generator exhaust contains carbon monoxide. This is a poison you cannot see or smell.</p>		<p>Utiliser un générateur à l'intérieur peut VOUS TUER EN QUELQUES MINUTES. Les gaz d'échappement du générateur contiennent du monoxyde de carbone, un poison que vous ne pouvez ni voir ni sentir.</p>	
		<p>Ne jamais faire fonctionner dans une maison ou un garage, MÊME SI les portes et les fenêtres sont ouvertes.</p>	<p>Utiliser uniquement à l'EXTÉRIEUR et à bonne distance des fenêtres, portes et événements.</p>
<p>NEVER use inside a home or garage, EVEN IF doors and windows are open.</p>	<p>Only use OUTSIDE and far away from windows, doors, and vents.</p>		

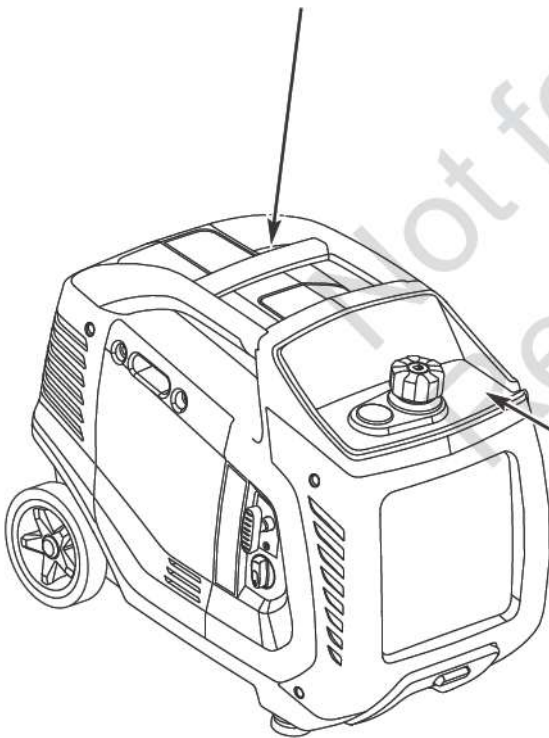

⚠ WARNING	
<p>Fire Hazard. Fuel is flammable which could cause burns resulting in death or serious injury. DO NOT fill fuel above baffle. Always allow space for fuel expansion.</p>	
⚠ AVERTISSEMENT	
<p>Risque d'incendie. L'essence est inflammable et peut causer des blessures entraînant la mort ou des blessures graves. NE PAS remplir le réservoir au-dessus du niveau du déflecteur. Toujours maintenir un espace vide suffisant pour permettre au carburant de se dilater.</p>	

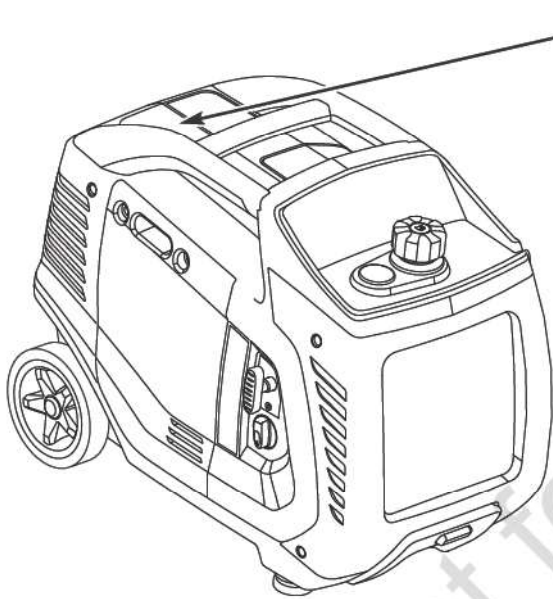

WARNING ⚠️ AVERTISSEMENT



Failure to read and follow the operator's manual, all warnings and operating instructions could result in death or serious injury.

Prière de lire et suivre toutes les directives du manuel d'utilisation, sans quoi la mort, des blessures graves pourraient survenir.



Poisonous Gas Hazard. Engine exhaust contains carbon monoxide, a poisonous gas that could kill you in minutes. You CANNOT smell it, see it, or taste it.

- Operate this product ONLY outside far away from windows, doors and vents.

- Install battery operated carbon monoxide alarms in home.

Risque d'empoisonnement au gaz. Les émanations du moteur contiennent du monoxyde de carbone, un gaz poison pouvant vous tuer en l'espace de quelques minutes. Il vous est IMPOSSIBLE de le sentir, de le voir, ou de le goûter.

- Mettez ce produit en marchant SEULEMENT à l'extérieur et loin des fenêtres, portes ou entrées de ventilation.

- Installez chez vous une alarme détectant le monoxyde de carbone.



Fire Hazard. Fuel and its vapors are flammable which could cause burns resulting in death or serious injury.

- Turn engine off and let it cool at least 2 minutes before refueling.

- Never add fuel to a hot or running generator.

Risque d'incendie. L'essence et ses vapeurs sont inflammables et peuvent causer des brûlures entraînant la mort ou des blessures graves.

- Éteignez le moteur et laissez-le refroidir pendant au moins 2 minutes avant d'y mettre de l'essence.

- N'ajoutez jamais d'essence dans une génératrice en fonction ou chaude.



Fire Hazard. Hot exhaust and reflective exhaust gases could cause burns and fires resulting in death or serious injury. Keep at least 5 ft.

(1.5 m) clearance from any combustibles or structures, including overhead.

Risque d'incendie. Les gaz d'échappement et les gaz d'échappement réfléchis peuvent causer des brûlures et des feux entraînant la mort ou des blessures graves.

Demeurez à au moins 1,5 m (5 pi) de tous combustibles ou structures, incluant au-dessus de vous.



Shock Hazard. Generator voltage could cause electrical shock resulting in death or serious injury.

- Transfer switch must be used when connecting to a building's electrical system.

- Do not run generator in rain or wet weather.

Risque de chocs électriques. Le voltage de la génératrice peut causer des chocs électriques entraînant la mort ou des blessures graves.

- L'interrupteur de transfert doit être utilisé lorsque vous connectez l'appareil au système électrique d'un édifice.

- Ne faites pas fonctionner la génératrice sous la pluie ou dans un climat humide.



Burn Hazard. Muffler area could cause burns.

- Do not touch hot parts
- Avoid hot exhaust gases.

Risques de brûlures. La zone autour du pot d'échappement pourrait être chaude et causer des brûlures.

- Ne touchez pas aux parties chaudes.
- Évitez les gaz d'échappement chauds.

Equipment Description



Read this manual carefully and become familiar with your generator. Know its applications, its limitations and any hazards involved.

The generator is an engine-driven, revolving field, alternating and direct current (AC & DC) generator. It was designed to supply electrical power for operating compatible electrical lighting, appliances, tools and motor loads. The generator's revolving field is driven at about 4,500 rpm (with POWERSMART mode switch off) by a single-cylinder engine.

NOTICE Exceeding generator's wattage/ampere capacity can damage generator and/or electrical devices connected to it.

- DO NOT exceed the generator's wattage/ampere capacity. See *Don't Overload Generator* in the *Operation* section.

Every effort has been made to ensure that the information in this manual is both accurate and current. However, the manufacturer reserves the right to change, alter or otherwise improve the generator and this documentation at any time without prior notice.

The Emission Control System for this generator is warranted for standards set by the Environmental Protection Agency and the California Air Resources Board.

Important Safety Information

The manufacturer cannot possibly anticipate every possible circumstance that might involve a hazard. The warnings in this manual, and the tags and decals affixed to the unit are, therefore, not all-inclusive. If you use a procedure, work method or operating technique that the manufacturer does not specifically recommend, you must satisfy yourself that it is safe for you and others. You must also make sure that the procedure, work method or operating technique that you choose does not render the generator unsafe.

Safety Symbols and Meanings



Toxic Fumes



Kickback



Electrical Shock



Fire



Explosion



Operator's Manual



Moving Parts



Flying Objects



Hot Surface



Explosive Pressure



Chemical Burn

⚠ The safety alert symbol indicates a potential personal injury hazard. A signal word (DANGER, WARNING, or CAUTION) is used with the alert symbol to designate a degree or level of hazard seriousness. A safety symbol may be used to represent the type of hazard. The signal word **NOTICE** is used to address practices not related to personal injury.

⚠ **DANGER** indicates a hazard which, if not avoided, *will* result in death or serious injury.

⚠ **WARNING** indicates a hazard which, if not avoided, *could* result in death or serious injury.

⚠ **CAUTION** indicates a hazard which, if not avoided, *could* result in minor or moderate injury.

NOTICE address practices not related to personal injury.

⚠ **WARNING** The engine exhaust from this product contains chemicals known to the State of California to cause cancer, birth defects, or other reproductive harm.

⚠ **WARNING** Certain components in this product and related accessories contain chemicals known to the State of California to cause cancer, birth defects or other reproductive harm. Wash hands after handling.

⚠ DANGER

Using a generator indoors CAN KILL YOU IN MINUTES.

Generator exhaust contains carbon monoxide. This is a poison you cannot see or smell.



NEVER use inside a home or garage, EVEN IF doors and windows are open.



Only use OUTSIDE and far away from windows, doors, and vents.

⚠ WARNING POISONOUS GAS HAZARD. Engine exhaust contains carbon monoxide, a poisonous gas that could kill you in minutes. You CANNOT smell it, see it, or taste it. Even if you do not smell exhaust fumes, you could still be exposed to carbon monoxide gas.

- Operate this product ONLY outside far away from windows, doors and vents to reduce the risk of carbon monoxide gas from accumulating and potentially being drawn towards occupied spaces.
- Install battery-operated carbon monoxide alarms or plug-in carbon monoxide alarms with battery back-up according to the manufacturer's instructions. Smoke alarms cannot detect carbon monoxide gas.
- DO NOT run this product inside homes, garages, basements, crawlspaces, sheds, or other partially-enclosed spaces even if using fans or opening doors and windows for ventilation. Carbon monoxide can quickly build up in these spaces and can linger for hours, even after this product has shut off.
- ALWAYS place this product downwind and point the engine exhaust away from occupied spaces.

If you start to feel sick, dizzy, or weak while using this product, shut it off and get to fresh air RIGHT AWAY. See a doctor. You may have carbon monoxide poisoning.

⚠ WARNING Storage batteries give off explosive hydrogen gas during recharging. Hydrogen gas stays near battery for a long time after battery has been charged. Slightest spark could ignite hydrogen causing explosion resulting in death or serious injury. Battery electrolyte fluid contains acid and is extremely caustic. Contact with battery fluid could cause chemical burns resulting in serious injury.

- DO NOT allow any open flame, spark, heat, or lit cigarette during and for several minutes after charging a battery.
- Wear protective goggles, rubber apron, and rubber gloves.
- DO NOT continue to charge a battery that becomes hot or is fully charged.
- DO NOT leave battery unattended.

⚠ WARNING Starter cord kickback (rapid retraction) will pull hand and arm toward engine faster than you can let go which could cause broken bones, fractures, bruises, or sprains resulting in serious injury.

- When starting engine, pull cord slowly until resistance is felt and then pull rapidly to avoid kickback.
- NEVER start or stop engine with electrical devices plugged in and turned on.

⚠ WARNING Fuel and its vapors are extremely flammable and explosive which could cause burns, fire or explosion resulting in death or serious injury.

WHEN ADDING OR DRAINING FUEL

- Turn generator engine OFF and let it cool at least 2 minutes before removing fuel cap. Loosen cap slowly to relieve pressure in tank.
- Fill or drain fuel tank outdoors.
- DO NOT overfill tank. Allow space for fuel expansion.
- If fuel spills, wait until it evaporates before starting engine.
- Keep fuel away from sparks, open flames, pilot lights, heat, and other ignition sources.
- Check fuel lines, tank, cap and fittings frequently for cracks or leaks. Replace if necessary.
- DO NOT light a cigarette or smoke.

WHEN STARTING EQUIPMENT

- Ensure spark plug, muffler, fuel cap, and air cleaner are in place.
- DO NOT crank engine with spark plug removed.

WHEN OPERATING EQUIPMENT

- DO NOT operate this product inside any building, carport, porch, mobile equipment, marine applications, or enclosure.
- DO NOT tip engine or equipment at angle which causes fuel to spill.
- DO NOT stop engine by moving choke control to CHOKE position (I\1).

WHEN TRANSPORTING, MOVING OR REPAIRING EQUIPMENT

- Transport/move/repair with fuel tank EMPTY or with fuel shutoff valve OFF.
- DO NOT tip engine or equipment at angle which causes fuel to spill.
- Disconnect spark plug wire.

WHEN STORING FUEL OR EQUIPMENT WITH FUEL IN TANK



- Store away from furnaces, stoves, water heaters, clothes dryers, or other appliances that have pilot light or other ignition source because they could ignite fuel vapors.

⚠ WARNING

- This generator does not meet U. S. Coast Guard Regulation 33CFR-183 and should not be used on marine applications.
- Failure to use the appropriate U. S. Coast Guard approved generator could result in death or serious injury.



 **WARNING** Generator voltage could cause electrical shock or burn resulting in death or serious injury.

- DO NOT connect generator to a building's electrical system.
- DO NOT touch bare wires or receptacles.
- DO NOT use generator with electrical cords which are worn, frayed, bare or otherwise damaged.
- DO NOT operate generator in the rain or wet weather.
- DO NOT handle generator or electrical cords while standing in water, while barefoot, or while hands or feet are wet.
- DO NOT allow unqualified persons or children to operate or service generator.

  **WARNING** Exhaust heat/gases could ignite combustibles, structures or damage fuel tank causing a fire, resulting in death or serious injury.

Contact with muffler area could cause burns resulting in serious injury.

- DO NOT touch hot parts and AVOID hot exhaust gases.
 - Allow equipment to cool before touching.
 - Keep at least 5 feet (1.5 m) of clearance on all sides of generator including overhead.
 - It is a violation of California Public Resource Code, Section 4442, to use or operate the engine on any forest-covered, brush-covered, or grass-covered land unless the exhaust system is equipped with a spark arrester, as defined in Section 4442, maintained in effective working order. Other states or federal jurisdictions may have similar laws.
- Contact the original equipment manufacturer, retailer, or dealer to obtain a spark arrester designed for the exhaust system installed on this engine.
- Replacement parts must be the same and installed in the same position as the original parts.

  **WARNING** Unintentional sparking could cause fire or electric shock resulting in death or serious injury.

WHEN ADJUSTING OR MAKING REPAIRS TO YOUR GENERATOR

- Disconnect the spark plug wire from the spark plug and place the wire where it cannot contact spark plug.

WHEN TESTING FOR ENGINE SPARK

- Use approved spark plug tester.
- DO NOT check for spark with spark plug removed.

 **WARNING** Starter and other rotating parts could entangle hands, hair, clothing, or accessories resulting in serious injury.

- NEVER operate generator without protective housing or covers.
- DO NOT wear loose clothing, jewelry or anything that could be caught in the starter or other rotating parts.
- Tie up long hair and remove jewelry.

 **CAUTION** Excessively high operating speeds could result in minor injury.

Excessively low operating speeds impose a heavy load.

- DO NOT tamper with governor spring, links or other parts to increase engine speed. Generator supplies correct rated frequency and voltage when running at governed speed.
- DO NOT modify generator in any way.

NOTICE Exceeding generators wattage/amperage capacity could damage generator and/or electrical devices connected to it.

- DO NOT exceed the generator's wattage/amperage capacity. See *Don't Overload Generator* in the *Operation* section.
- Start generator and let engine stabilize before connecting electrical loads.
- Connect electrical loads in OFF position, then turn ON for operation.
- Turn electrical loads OFF and disconnect from generator before stopping generator.

NOTICE Improper treatment of generator could damage it and shorten its life.

- Use generator only for intended uses.
- If you have questions about intended use, ask dealer or contact local service center.
- Operate generator only on level surfaces.
- DO NOT expose generator to excessive moisture, dust, dirt, or corrosive vapors.
- DO NOT insert any objects through cooling slots.
- If connected devices overheat, turn them off and disconnect them from generator.
- Shut off generator if:
 - electrical output is lost;
 - equipment sparks, smokes, or emits flames;
 - unit vibrates excessively.

Assembly

Your generator requires some assembly and is ready for use after it has been properly serviced with the recommended fuel and oil.

If you have any problems with the assembly of your generator, please call the generator helpline at **(800) 743-4115**. If calling for assistance, please have the model, revision, and serial number from the identification label available. See *Generator Features and Controls* for identification label location.

Unpack Generator

1. Set the carton on a rigid, flat surface.
2. Remove everything from carton except generator.
3. Open carton completely by cutting each corner from top to bottom.

The generator is supplied with:

- Battery charge cables
- Operator's manual
- Engine oil bottle
- Tool kit
- RV adapter plug

Add Engine Oil

1. Place generator on a level surface.
2. Loosen the two maintenance cover screws and remove the side maintenance cover.

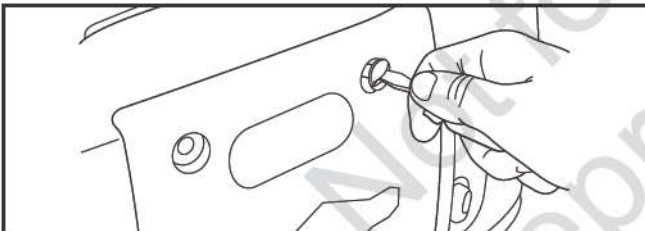

3. Clean area around oil fill and remove yellow oil fill cap.

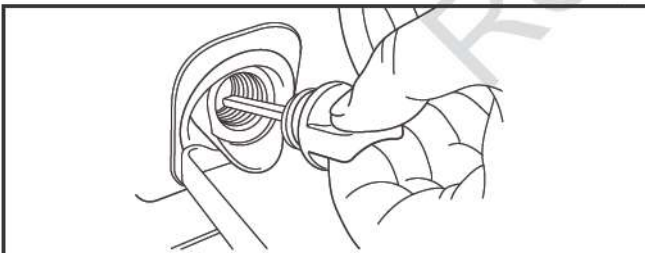

4. Using oil funnel (optional), slowly pour contents of provided oil bottle into oil fill opening to the point of overflowing at oil fill cap.

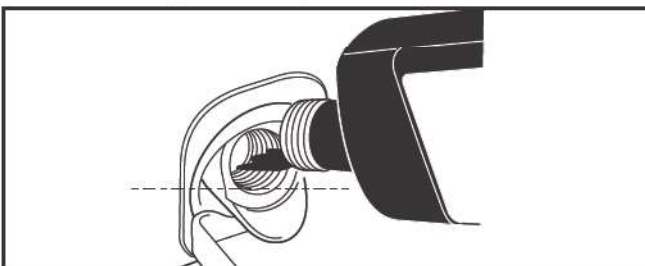

NOTICE Improper treatment of generator could damage it and shorten its life.

- DO NOT attempt to crank or start the engine before it has been properly serviced with the recommended oil. This could result in an engine failure.

5. Replace oil fill cap and fully tighten.
6. Replace the maintenance cover and hand tighten the two maintenance cover screws.

Add Fuel

Fuel must meet these requirements:

- Clean, fresh, unleaded gasoline.
- A minimum of 87 octane/87 AKI (91 RON). For high altitude use, see *High Altitude*.
- Gasoline with up to 10% ethanol (gasohol) is acceptable.

NOTICE Use of unapproved fuels could damage generator and voids warranty.

- DO NOT use unapproved gasoline such as E15 and E85.
- DO NOT mix oil in gasoline or modify engine to run on alternate fuels.

To protect the fuel system from gum formation, mix in a fuel stabilizer when adding fuel. See *Storage*. All fuel is not the same. If you experience starting or performance problems after using fuel, switch to a different fuel provider or change brands. This engine is certified to operate on gasoline. The emission control system for this engine is EM (Engine Modifications).

WARNING Fuel and its vapors are extremely flammable and explosive which could cause burns, fire or explosion resulting in death or serious injury.

WHEN ADDING FUEL

- Turn generator engine OFF and let it cool at least 2 minutes before removing fuel cap. Loosen cap slowly to relieve pressure in tank.
- Fill fuel tank outdoors.
- DO NOT overfill tank. Allow space for fuel expansion.
- If fuel spills, wait until it evaporates before starting engine.
- Keep fuel away from sparks, open flames, pilot lights, heat, and other ignition sources.
- Check fuel lines, tank, cap and fittings frequently for cracks or leaks. Replace if necessary.
- DO NOT light a cigarette or smoke.

1. Clean area around fuel fill cap, remove cap.
2. Slowly add unleaded fuel to red fuel level indicator (A) in fuel tank. Be careful not to fill above the indicator. This allows adequate space for fuel expansion.

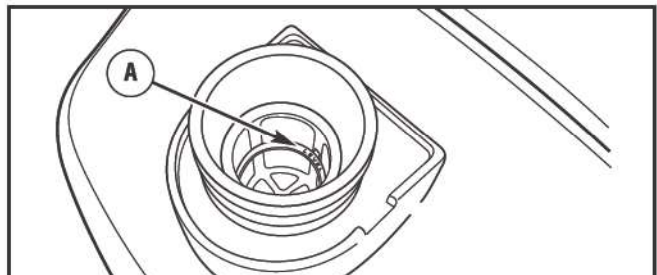

3. Install fuel cap and let any spilled fuel evaporate before starting engine.

High Altitude

At altitudes over 5,000 feet (1524 meters), a minimum 85 octane / 85 AKI (89 RON) gasoline is acceptable. To remain emissions compliant, high altitude adjustment is required. Operation without this adjustment will cause decreased performance, increased fuel consumption, and increased emissions. See a Briggs & Stratton Authorized Dealer for high altitude adjustment information. Operation of the engine at altitudes below 2,500 feet (762 meters) with the high altitude kit is not recommended.

Grounding Fastener

The generator neutral is floating, which means that the AC stator winding is isolated from the grounding fastener and the AC receptacle ground pins. On a floating neutral generator the AC receptacle ground pins are not functional. Electrical devices, such as a GFCI, requiring a functioning AC receptacle ground pin will not operate.

Special Requirements

There may be Federal, local codes, or ordinances that apply to the intended use of the generator. Please consult a qualified electrician, electrical inspector, or the local agency having jurisdiction:

- This generator has a floating neutral and is not for use on job sites requiring a bonded neutral.

Portable Generator Location

Before starting the portable generator there are two equally important safety concerns regarding carbon monoxide (CO) poisoning and fire that must be addressed.

NOTICE Satisfying the RISK OF CARBON MONOXIDE POISONING location requirements may not satisfy the fire location requirements. Satisfying the RISK OF FIRE location requirements may not satisfy the CARBON MONOXIDE POISONING location requirements.



Operation Location of Portable Generator to REDUCE THE RISK OF CARBON MONOXIDE POISONING

All fossil fuel burning equipment, such as a portable generator, contains carbon monoxide (CO) gas in the engine exhaust, a poisonous gas that could kill you in minutes. You CANNOT smell it, see it, or taste it. Even if you do not smell exhaust fumes, you could still be exposed to carbon monoxide gas. The following must be completed prior to starting the portable generator engine:

⚠ DANGER

Using a generator indoors CAN KILL YOU IN MINUTES.

Generator exhaust contains carbon monoxide. This is a poison you cannot see or smell.

 NEVER use inside a home or garage, EVEN IF doors and windows are open.	 Only use OUTSIDE and far away from windows, doors, and vents.
--	---

- By law it is required in many states to have a Carbon Monoxide (CO) alarm (A) in operating condition in your home. Install/maintain battery-operated carbon monoxide alarms or plug-in carbon monoxide alarms with battery back-up according to the manufacturer's instructions. A CO alarm is an electronic device that detects hazardous levels of CO. When there is a buildup of CO, the alarm will alert the occupants by flashing visual indicator light and alarm. Smoke alarms cannot detect CO gas.

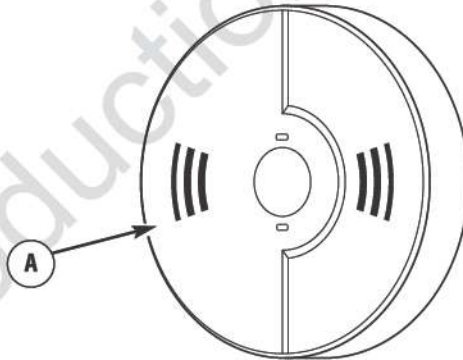

- Operate this product ONLY outside far away from windows, doors and vents to reduce the risk of carbon monoxide gas from accumulating and potentially being drawn towards occupied spaces.
- DO NOT run this product inside homes, garages, basements, crawlspaces, sheds, or other partially-enclosed spaces even if using fans or opening doors and windows for ventilation. Carbon monoxide can quickly build up in these spaces and can linger for hours, even after this product has shut off.

- Your neighbor(s) home may be exposed to the engine exhaust from your portable generator and must be considered when deciding on a location for the safe operation of your portable generator.
- ALWAYS place this product downwind and point the engine exhaust away from occupied spaces.

If you start to feel sick, dizzy, or weak while using this product, shut it off and get to fresh air RIGHT AWAY. See a doctor. You may have carbon monoxide poisoning.

EXAMPLE OF LOCATION TO REDUCE THE RISK OF CARBON MONOXIDE POISONING

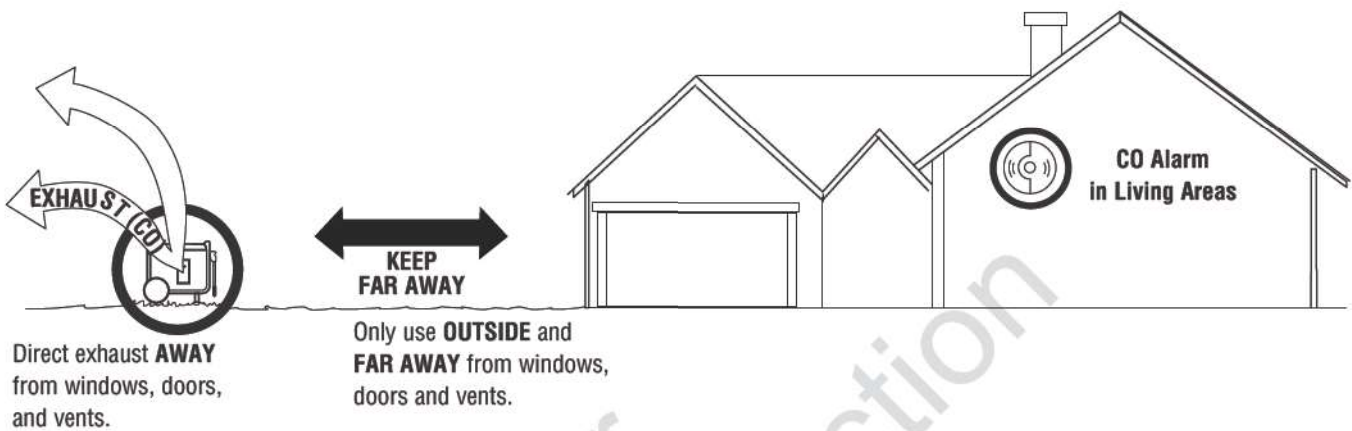

DO NOT OPERATE IN ANY OF THE FOLLOWING LOCATIONS

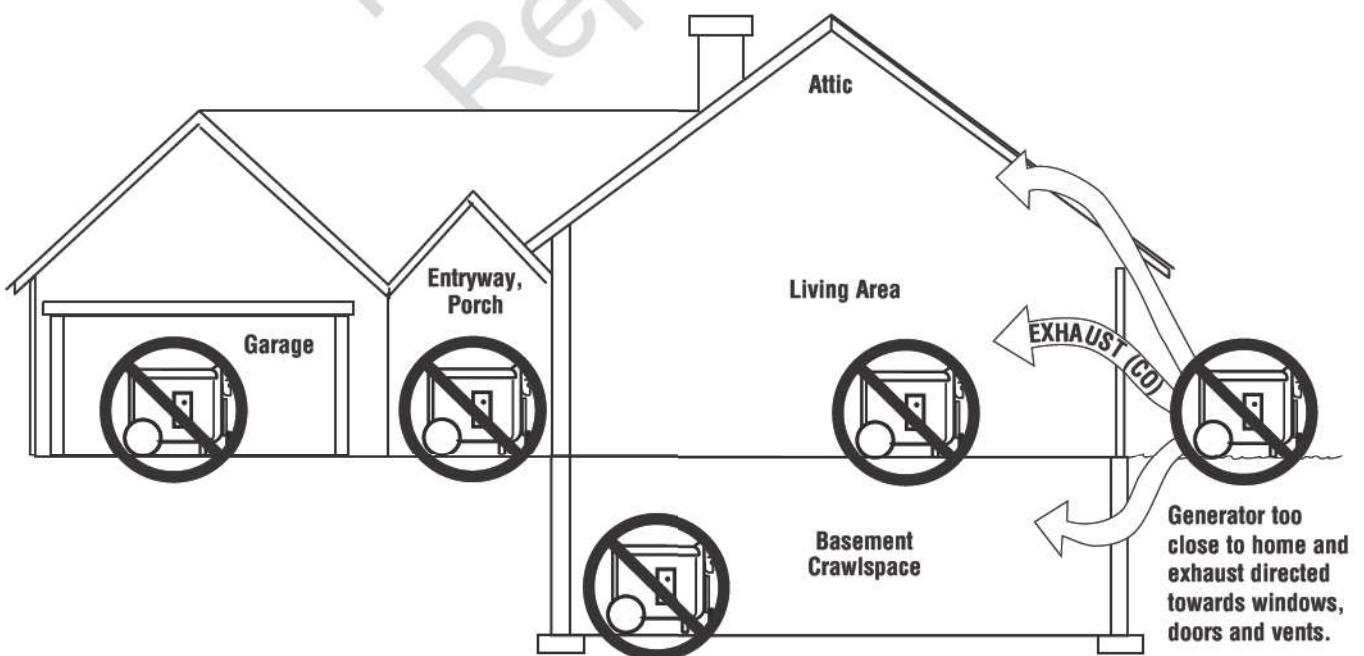

Operation Location of Portable Generator to REDUCE THE RISK OF FIRE

⚠ WARNING Exhaust heat/gases could ignite combustibles, structures or damage fuel tank causing a fire, resulting in death or serious injury.



- Portable generator must be at least 5 feet (1.5 m) from any structure, overhang, trees, windows, doors, any wall opening, shrubs, or vegetation over 12 inches (30.5 cm) in height.
- DO NOT place portable generator under a deck or other type of structure that may confine airflow.
- Smoke alarm(s) MUST be installed and maintained indoors according to the manufacturer's instructions/recommendations. Carbon monoxide alarms cannot detect smoke.
- DO NOT place portable generator in manner other than shown.

EXAMPLE OF LOCATION TO REDUCE THE RISK OF FIRE

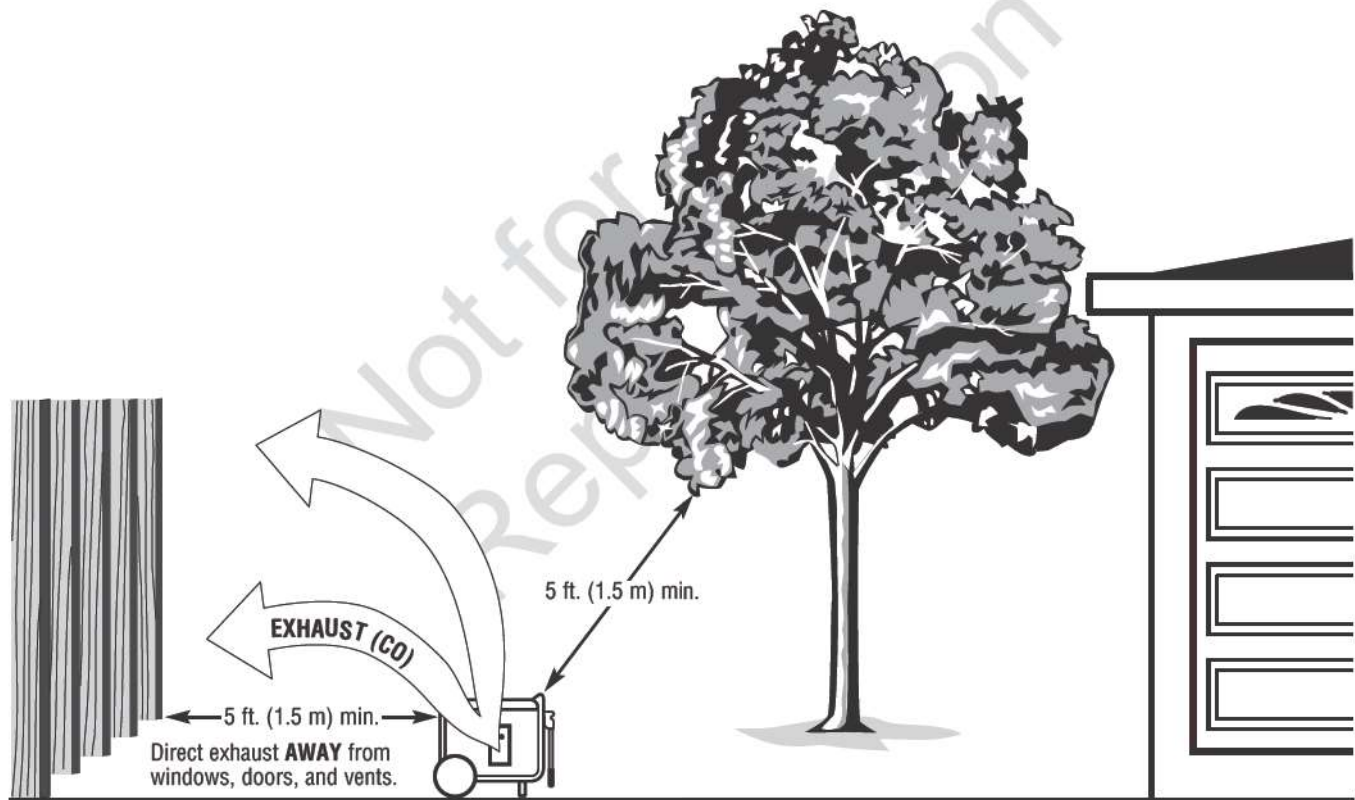

Features and Controls



Read this Operator's Manual and safety rules before operating your generator.

Compare the illustrations with your generator, to familiarize yourself with the locations of various controls and adjustments. Save this manual for future reference.

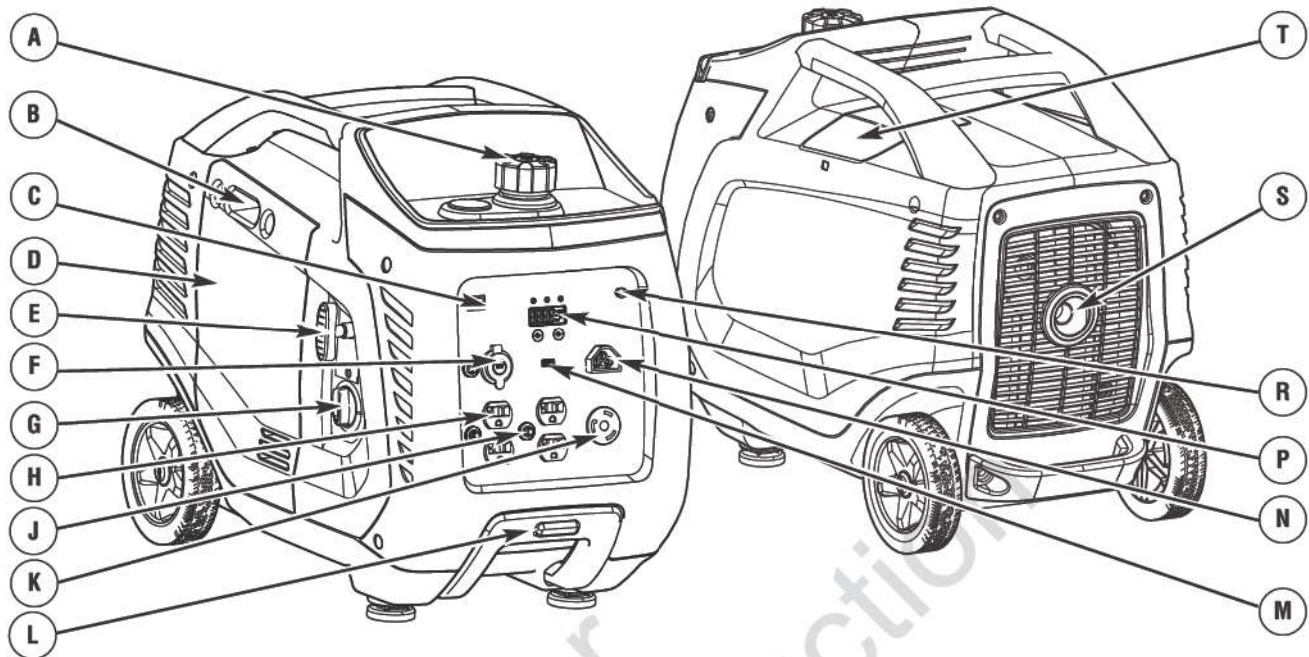

A - Fuel Tank — Capacity of 5.7 L (1.5 U.S. gallons).

B - Choke Lever — Used when starting a cold engine.

C - POWERSMART Switch— Use this switch to turn the POWERSMART mode on and off.

D - Side Maintenance Cover — Remove to gain access to the air cleaner and oil service.

E - Recoil Starter — Used to start the engine manually.

F - 12 Volt DC Receptacle — Use this receptacle with battery charge cables to charge a 12 Volt battery. This receptacle is protected by a push to reset circuit breaker.

G - Engine Switch — Set this switch to ON (I) before using recoil starter. Set switch to OFF (O) to stop engine. Also turns fuel valve on and off.

H - 120 Volt AC, 20 Amp, Duplex Receptacle — May be used to supply electrical power for the operation of 120 Volt AC, 20 Amp, single phase, 60 Hz electrical, lighting, appliance, tool, and motor loads.

J - Circuit Breakers — The 120 Volt AC, 20A duplex receptacles are provided with “push to reset” circuit breakers to protect the generator against electrical overload.

K - 120 Volt AC, 30 Amp Locking Receptacle — May be used to supply electrical power for the operation of 120 Volt AC, 30 Amp, single phase, 60 Hz electrical lighting, appliance, tool and motor loads.

L - Retractable Handle — Press button and pull handle out to move generator. Press button to push handle back in.

M - USB Port — Use this port to recharge most USB powered devices.

N - Parallel Operation Port — Use this port with optional parallel operation kit to allow two generators to run in parallel.

P - Statstation™ LCD Screen — Built in LCD screen to monitor certain features on the generator. See *STATSTATION™*.

R - Grounding Fastener — Consult your local agency having jurisdiction for grounding requirements in your area.

S - Spark Arrester Muffler — Exhaust muffler lowers engine noise and is equipped with a spark arrester screen.

T - Top Maintenance Cover — Remove to gain access to the spark plug.

Items Not Shown:

Air Cleaner (under side maintenance cover) — Protects engine by filtering dust and debris out of intake air.

Identification Label (under retractable handle) — Provides model, revision, and serial number of generator. Please have these readily available when calling for assistance.

Oil Fill Cap (under side maintenance cover) — Check and add engine oil here.

Cord Sets and Receptacles

Use only high quality, well-insulated, grounded extension cords with the generator's receptacles. Inspect extension cords before each use.

Check the ratings of all extension cords before you use them. Check the operator's manuals of devices for the manufacturer's recommendations.

WARNING Damaged or overloaded electrical cords could overheat, arc, and burn resulting in death or serious injury.



- ONLY use cords rated for your loads.
- Follow all safeties on electrical cords.
- Inspect cord sets before each use.

120 Volt AC, 30 Amp Locking Receptacle

Use a NEMA L5-30 plug with this receptacle. Connect a 3-wire cord set rated for 125 Volt AC loads at 30 Amps to the plug.

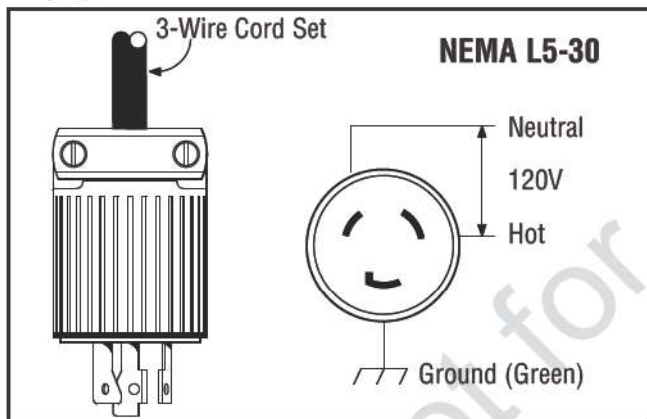

Use this receptacle to operate 120 Volt AC, 60 Hz, single phase loads requiring up to 2,600 watts (2.6 kW) of power at 21.6 Amps.

NOTICE Receptacles may be marked with rating value greater than generator output capacity.

- NEVER attempt to power a device requiring more amperage than generator or receptacle can supply.
- DO NOT overload the generator. See *Don't Overload Generator*.

120 Volt AC, 20 Amp, Duplex Receptacles

The duplex receptacles are protected against overload by push-to-reset circuit breakers.

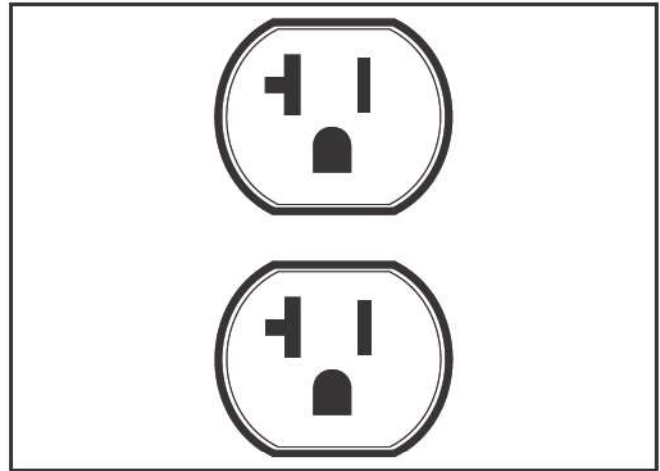

Use receptacle to operate 120 Volt AC, single-phase, 60 Hz electrical loads requiring up to 2,400 watts (2.4 kW) at 20 Amps of current. Use cord sets that are rated for 125 Volt AC loads at 20 Amps (or greater).

5 Volt DC USB Port

The maximum current available for the USB port is 1 Amp at 5 Volts. The USB port allows you to recharge most USB powered devices with a USB charging cable (not included).

NOTICE For charging ITE (Information Technology Equipment) only.

12 Volt DC Receptacle

The maximum current available for the battery charge circuit is 5 Amps. A DC circuit breaker protects this receptacle from overloads. If an overload occurs, the circuit breaker will trip (push button pops out). Wait a few minutes and push the button in to reset the circuit breaker.

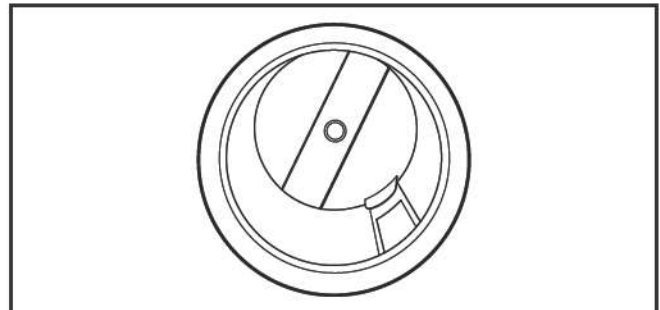

This receptacle allows you to recharge a 12 Volt automotive or utility style storage battery with the battery charge cable provided.

This receptacle can not be used to crank an engine having a discharged battery. See *Charging a Battery* before attempting to recharge a battery.

NOTICE When using the battery charge circuit and USB port, turn the POWERSMART switch to the OFF (0) position for best performance.

Parallel Operation Port

The parallel operation port allows you to connect two P3000 model inverter generators with an Briggs & Stratton approved parallel operation kit (optional equipment). When running in parallel, the total output of power is up to 4,800 watts (4.8 kW).

STATSTATION™

The control panel has a built in LCD display (A) to monitor the following features:

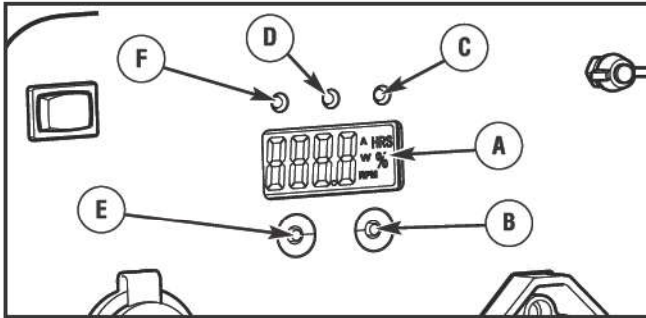

- Load Monitor (Total Generator Load)
- Hour Meter (Total Generator Hours)
- Maintenance Reminder (Engine Maintenance)

Load Monitor

The load monitor measures the output wattage (generator load) of all the generator receptacles and will display the percentage of total generator load.

Hour Meter

The LCD on the control panel also has a built in hour meter that displays and records how many hours your generator has run (up to 999.9).

Maintenance Reminder

The LCD on the control panel also has a built in maintenance reminder to alert you to change air filter, change oil, and change spark plug. The LCD display will flash every 50 hours for the different maintenance intervals. See *Maintenance Schedule* for different maintenance intervals.

Pressing the “View” button (B) will toggle between the flashing load percentage and the flashing hour display. Once maintenance has been performed, you must push and hold the “View” button on the control panel for a minimum of 3 seconds to stop the display from flashing and return it to normal operation.

Output Indicator **OK!**

The green LED output indicator light (C) comes on when the generator is operating normally. It indicates that the generator is producing power at the receptacles.

Overload Alarm

The red LED overload alarm light (D) comes on and cuts power to the receptacles if you overload the generator. The green output indicator light will also go off. If the generator was overloaded, you must turn off and unplug all electrical loads, press the “Reset” button (E) on the generator control panel and then plug in and restart electrical loads one at a time to continue in normal operating mode.

Low Oil Indicator

The low oil indicator system is designed to prevent engine damage caused by not enough engine oil. If the engine oil level drops below a preset level, the yellow LED low oil indicator light (F) comes on and an oil level switch will stop the engine. If the engine stops or the yellow LED low oil indicator light comes on when you pull the recoil handle, check the engine oil level.

Operation

Starting the Engine

Disconnect all electrical loads from the generator. Use the following start instructions:

1. Make sure unit is on a level surface.

NOTICE Failure to start and operate the unit on a level surface will cause the unit not to start or shut down during operation.

2. Turn the engine switch (A) to the ON (I) position.

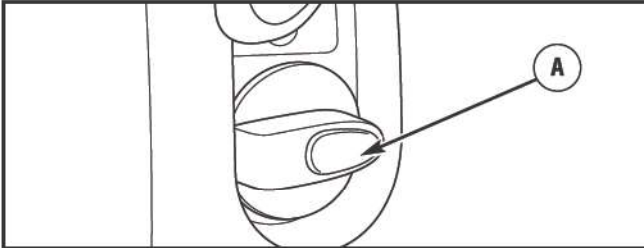

3. Push choke lever (B) to CHOKE (I↖) position.

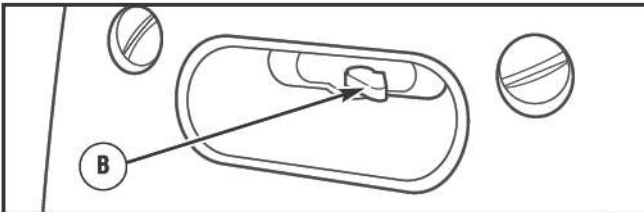

NOTICE To help start the engine for the very first time, after running out of fuel or after a long period of storage, fill fuel tank as described in *Add Fuel*. It will require more than several start attempts until the air in the fuel system has been purged.

- 4A. Grasp recoil handle and pull slowly until slight resistance is felt. Then pull rapidly to start engine.
 - If engine starts, proceed to step 6.
 - If engine fails to start, proceed to step 5.

WARNING Starter cord kickback (rapid retraction) will pull hand and arm toward engine faster than you can let go which could cause broken bones, fractures, bruises, or sprains resulting in serious injury.



- When starting engine, pull cord slowly until resistance is felt and then pull rapidly to avoid kickback.
- NEVER start or stop engine with electrical devices plugged in and turned on.

To start engine thereafter:

- 4B. Grasp recoil handle and pull slowly until slight resistance is felt. Then pull rapidly one time only to start engine.
 - If engine starts, proceed to step 6.
 - If engine fails to start, proceed to step 5.
5. Move choke lever to half choke position, and pull recoil handle twice.
 - If engine fails to start, repeat steps 3 thru 4.
6. Slowly move choke lever to RUN (I↗) position. If engine falters, move choke lever to half choke position until engine runs smoothly, and then to RUN (I↗) position.

NOTICE If engine floods, move choke lever to RUN (I↗) position and crank until engine starts.

NOTICE If engine starts after 3 pulls but fails to run, or if unit shuts down during operation, make sure unit is on a level surface and check for proper oil level in crankcase. This unit is equipped with a low oil protection device. If so, oil must be at proper level for engine to start.

WARNING Exhaust heat/gases could ignite combustibles, structures or damage fuel tank causing a fire, resulting in death or serious injury.



Contact with muffler area could cause burns resulting in serious injury.

- DO NOT touch hot parts and AVOID hot exhaust gases.
- Allow equipment to cool before touching.
- Keep at least 5 feet (1.5 m) of clearance on all sides of generator including overhead.
- It is a violation of California Public Resource Code, Section 4442, to use or operate the engine on any forest-covered, brush-covered, or grass-covered land unless the exhaust system is equipped with a spark arrester, as defined in Section 4442, maintained in effective working order. Other states or federal jurisdictions may have similar laws.

Contact the original equipment manufacturer, retailer, or dealer to obtain a spark arrester designed for the exhaust system installed on this engine.

- Replacement parts must be the same and installed in the same position as the original parts.

Connecting Electrical Loads

1. Make sure the green output indicator light comes on (it may take up to three seconds).
2. Let engine stabilize and warm up for a few minutes after starting.
3. Plug in and turn on the desired 120 Volt AC, single phase, 60 Hz electrical loads.

NOTICE When plugging into the 120 Volt duplex receptacles, plug items to be powered in sequence as shown below.

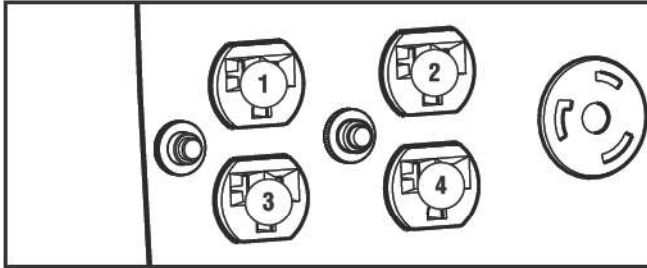

NOTICE

- DO NOT connect 240 Volt loads to the 120 Volt receptacles.
- DO NOT connect 3-phase loads to the generator.
- DO NOT connect 50 Hz loads to the generator.
- DO NOT OVERLOAD THE GENERATOR. See *Don't Overload Generator*.

NOTICE Exceeding generators wattage/amperage capacity could damage generator and/or electrical devices connected to it.

- DO NOT exceed the generator's wattage/amperage capacity. See *Don't Overload Generator* in the *Operation* section.
- Start generator and let engine stabilize before connecting electrical loads.
- Connect electrical loads in OFF position, then turn ON for operation.
- Turn electrical loads OFF and disconnect from generator before stopping generator.

Parallel Operation

Two Briggs & Stratton P3000 inverter generators can be run in parallel with a Briggs & Stratton parallel operation kit (optional equipment) for a total output of power of up to 4,800 watts (4.8 kW).

NOTICE Total electrical load connected to the parallel kit must not exceed 4,800 watts (4.8 kW).

See the parallel operation kits instruction sheet for detailed instructions on installation and operation of the connected generators.

NOTICE

- Turn electrical loads OFF and disconnect from both generators.
- The POWERSMART switch must be in the same position on both generators.
- Connect the power cables to both generators before starting the engines. See instruction sheet supplied with parallel kit.
- Start engine on one of the inverter generators according to *Starting the Engine* in the *Operation* section.
- Once the green LED output indicator light on the first generator is steady, start second generator.
- Connect and turn on electrical loads to the parallel panel receptacles.
- DO NOT disconnect power cables after engines have been started.
- Shut down engines as described in *Stopping the Engine*.

Stopping the Engine

1. Turn OFF and unplug all electrical loads from generator panel receptacles. NEVER start or stop engine with electrical devices plugged in and turned ON.
2. Let engine run at no-load for several minutes to stabilize internal temperatures of engine and generator.

⚠ WARNING Fuel and its vapors are extremely flammable and explosive which could cause burns, fire or explosion resulting in death or serious injury.



- DO NOT stop engine by moving choke lever to CHOKE position (I\|).

3. Turn engine switch to the OFF (0) position.

POWERSMART Mode

This feature is designed to greatly improve fuel economy. **When this switch is turned ON**, the engine speed will increase as electrical loads are connected, and decreased as electrical loads are removed.

With the switch off, the engine will run at full governed speed. **Always have the switch OFF when starting and stopping the engine.**

NOTICE Always have the switch OFF when starting or stopping the generator or when using the DC receptacle.

Charging a Battery

Your generator has the capability of recharging a discharged 12 Volt automotive or utility style storage battery.

NOTICE

- Not for use with any other type of battery.
- DO NOT use the unit to charge any 6 Volt batteries.
- DO NOT use the unit to crank an engine having a discharged battery.

⚠ WARNING Storage batteries give off explosive hydrogen gas during recharging. Hydrogen gas stays near battery for a long time after battery has been charged. Slightest spark could ignite hydrogen causing explosion resulting in death or serious injury. Battery electrolyte fluid contains acid and is extremely caustic. Contact with battery fluid could cause chemical burns resulting in serious injury.



- DO NOT allow any open flame, spark, heat, or lit cigarette during and for several minutes after charging a battery.
- Wear protective goggles, rubber apron, and rubber gloves.
- DO NOT continue to charge a battery that becomes hot or is fully charged.
- DO NOT leave battery unattended.

To recharge 12 Volt batteries, proceed as follows:

1. Make sure POWERSMART switch is in OFF (0) position.
2. If necessary, clean battery posts or terminals.

⚠ WARNING Battery posts, terminals and related accessories contain lead and lead compounds, chemicals known to the State of California to cause cancer and reproductive harm. Wash hands after handling.

3. Check fluid level in all battery cells. If necessary, add ONLY distilled water to cover separators in battery cells. **DO NOT use tap water.**
4. If the battery is equipped with vent caps, make sure they are installed and are tight.
5. Connect battery charge cable clamp with **red** handle to battery post or terminal indicated by **Positive, POS** or **(+)**.

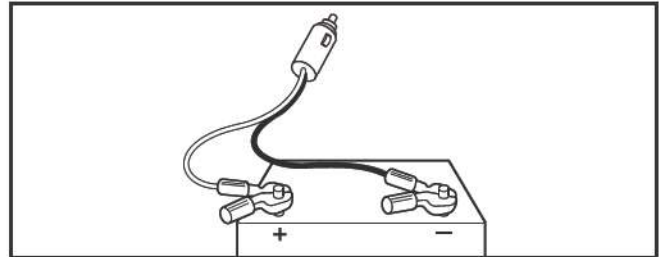

6. Connect battery charge cable clamp with **black** handle to battery post or terminal indicated by **Negative, NEG**, or **(-)**.
7. Connect battery charge cable connector plug to the 12 Volt DC panel receptacle.
8. Start generator as described in *Starting The Engine*. Let the engine run while battery recharges.

NOTICE Normally a period of 30 to 120 minutes is sufficient to recharge a weak battery.

9. When battery has charged, shut down engine as described in *Stopping The Engine*.
10. Remove the battery charging cable from the generator and then disconnect from the battery posts.

NOTICE Use an automotive hydrometer to test battery state of charge and condition. Follow the hydrometer manufacturer's instructions carefully. Generally, a battery is considered to be at 100% state of charge when specific gravity of its fluid (as measured by hydrometer) is 1.260 or higher.

Don't Overload Generator

Capacity

You must make sure your generator can supply enough rated (running) and surge (starting) watts for the items you will power at the same time. Follow these simple steps:

1. Select the items you will power at the same time.
2. Total the rated (running) watts of these items. This is the amount of power your generator must produce to keep your items running. See Wattage Reference Guide.
3. Estimate how many surge (starting) watts you will need. Surge wattage is the short burst of power needed to start electric motor-driven tools or appliances such as a circular saw or refrigerator. Because not all motors start at the same time, total surge watts can be estimated by adding only the item(s) with the highest additional surge watts to the total rated watts from step 2.

Example:

Tool or Appliance	Rated (Running) Watts	Additional Surge (Starting) Watts
Window Fan	300	600
Deep Freezer	500	500
Television	500	—
Security System	180	—
Light (75 Watts)	75	—
	1555 Total Running Watts	600 Highest Surge Watts

Total Rated (Running) Watts = 1555
 Highest Additional Surge Watts = 600
 Total Generator Output Required = 2155

Power Management

To prolong the life of your generator and attached devices, it is important to take care when adding electrical loads to your generator. There should be nothing connected to the generator outlets before starting its engine. The correct and safe way to manage generator power is to sequentially add loads as follows:

1. With nothing connected to the generator, start the engine as described in this manual.
2. Plug in and turn on the first load, preferably the largest load you have.
3. Permit the generator output to stabilize (engine runs smoothly and attached device operates properly).
4. Plug in and turn on the next load.
5. Again, permit the generator to stabilize.
6. Repeat steps 4 and 5 for each additional load.

NEVER add more loads than the generator capacity. Take special care to consider surge loads in generator capacity, as described above.

Wattage Reference Guide		
Tool or Appliance	Rated* (Running) Watts	Additional Surge (Starting) Watts
Essentials		
Light Bulb - 75 watt	75	—
Deep Freezer	500	500
Sump Pump	800	1200
Refrigerator/Freezer - 18 cf	800	1600
Water Well Pump - 1/3 hp	1000	2000
Heating/Cooling		
Window AC - 10,000 BTU	1200	1800
Window Fan	300	600
Furnace Fan Blower - 1/2 hp	800	1300
Kitchen		
Microwave Oven - 1000 Watt	1000	—
Coffee Maker	1500	—
Electric Stove - Single Element	1500	—
Hot Plate	2500	—
Family Room		
DVD/CD Player	100	—
VCR	100	—
Stereo Receiver	450	—
Color Television - 27 in	500	—
Personal Computer w/17 in monitor	800	—
Other		
Security System	180	—
AM/FM Clock Radio	300	—
Garage Door Opener - 1/2 hp	480	520
Electric Water Heater - 40 gallon	4000	—
DIY		
Quartz Halogen Work Light	1000	—
Airless Sprayer - 1/3 hp	600	1200
Reciprocating Saw	960	960
Electric Drill - 1/2 hp	1000	1000
Circular Saw - 7-1/4 in	1500	1500
Miter Saw - 10 in	1800	1800
Table Planer - 6 in	1800	1800
Table Saw/Radial Arm Saw - 10 in	2000	2000
Air Compressor - 1-1/2 hp	2500	2500

* Wattages listed are approximate only. Check tool or appliance for actual wattage.

Maintenance

Maintenance Schedule

Follow the hourly or calendar intervals, whichever occurs first. More frequent service is required when operating in adverse conditions noted below.

Every 8 Hours or Daily
<ul style="list-style-type: none">• Clean debris• Check engine oil level
First 10 Hours
<ul style="list-style-type: none">• Change engine oil
Every 50 Hours
<ul style="list-style-type: none">• Service engine air cleaner and breather filter¹• Change engine oil¹
Every 100 Hours
<ul style="list-style-type: none">• Clean fuel strainer• Service spark plug• Inspect muffler and spark arrester

¹ Service more often under dirty or dusty conditions.

General Recommendations

Regular maintenance will improve the performance and extend the life of the generator. See any authorized dealer for service.

The generator's warranty does not cover items that have been subjected to operator abuse or negligence. To receive full value from the warranty, the operator must maintain the generator as instructed in this manual.

NOTICE Improper treatment of generator could damage it and shorten its life.

- NEVER operate generator without protective housing or covers to assure proper cooling.

Some adjustments will need to be made periodically to properly maintain your generator.

All service and adjustments should be made at least once each season. A new spark plug and clean air filter assure proper fuel-air mixture and help your engine run better and last longer. Follow the requirements in the *Maintenance Schedule* chart above.

Emissions Control

Maintenance, replacement, or repair of the emissions control devices and systems may be performed by any non-road engine repair establishment or individual.

However, to obtain "no charge" emissions control service, the work must be performed by a factory authorized dealer. See the *Emissions Warranty*.

- Generator is equipped with a G-trim engine.

Generator Maintenance

Generator maintenance consists of keeping the unit clean and dry. Operate and store the unit in a clean dry environment where it will not be exposed to excessive dust, dirt, moisture, or any corrosive vapors. Cooling air slots in the generator must not become clogged with snow, leaves, or any other foreign material.

NOTICE DO NOT use water or other liquids to clean generator. Liquids can enter engine fuel system, causing poor performance and/or failure to occur. In addition, if liquid enters generator through cooling air slots, some of the liquid will be retained in voids and cracks of the rotor and stator winding insulation. Liquid and dirt buildup on the generator internal windings will eventually decrease the insulation resistance of these windings.

Cleaning

Daily or before use, look around and underneath the generator for signs of oil or fuel leaks. Clean accumulated debris from inside and outside the generator. Keep the linkage, spring and other engine controls clean. Keep the area around and behind the muffler free from any combustible debris. Inspect cooling air slots and openings on generator. These openings must be kept clean and unobstructed.

Engine parts should be kept clean to reduce the risk of overheating and ignition of accumulated debris:

- Use a damp cloth to wipe exterior surfaces clean.

NOTICE Improper treatment of generator could damage it and shorten its life.

- DO NOT expose generator to excessive moisture, dust, dirt, or corrosive vapors.
- DO NOT insert any objects through cooling slots.
 - Use a soft bristle brush to loosen caked on dirt or oil.
 - Use a vacuum cleaner to pick up loose dirt and debris.

Cleaning Fuel Strainer

The fuel strainer helps prevent debris from entering the fuel system.

Clean the fuel strainer as follows:

1. Make sure generator is on a level surface.
2. Remove the fuel cap (A) and fuel strainer (B).

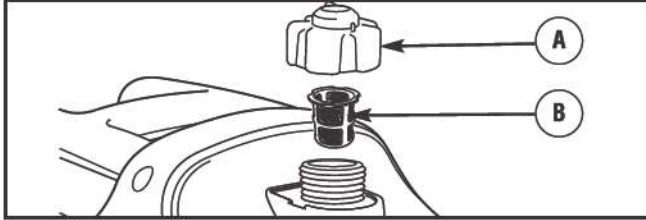

3. Wash fuel strainer in liquid detergent and water.
4. Wipe fuel strainer clean with a clean, dry cloth.
5. Carefully reinstall the fuel strainer and fuel cap.

Engine Maintenance

WARNING Unintentional sparking could cause fire or electric shock resulting in death or serious injury.

WHEN ADJUSTING OR MAKING REPAIRS TO YOUR GENERATOR

- Disconnect the spark plug wire from the spark plug and place the wire where it cannot contact spark plug.

WHEN TESTING FOR ENGINE SPARK

- Use approved spark plug tester.
- DO NOT check for spark with spark plug removed.

Oil

Oil Recommendations

We recommend the use of Briggs & Stratton Warranty Certified oils for best performance. Other high-quality detergent oils are acceptable if classified for service SF, SG, SH, SJ or higher. DO NOT use special additives.

Outdoor temperatures determine the proper oil viscosity for the engine. Use the chart to select the best viscosity for the outdoor temperature range expected.

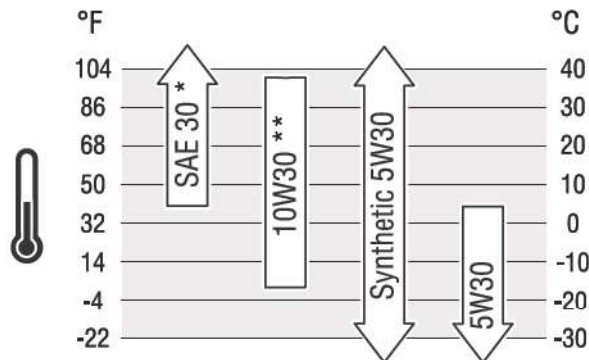

* Below 40°F (4°C) the use of SAE 30 will result in hard starting.

** Above 80°F (27°C) the use of 10W30 may cause increased oil consumption. Check oil level more frequently.

Checking Oil Level

Oil level should be checked prior to each use or at least every 8 hours of operation. Keep oil level maintained.

1. Make sure generator is on a level surface.
2. Loosen the side maintenance cover screws and remove the side maintenance cover.

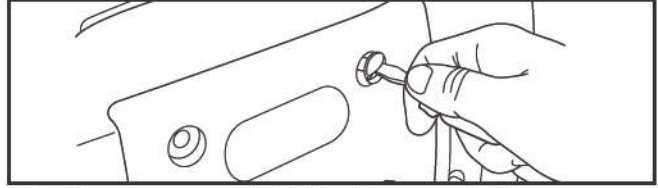

3. Clean area around oil fill and remove oil fill cap.
4. Verify oil is at the point of overflowing at oil fill opening.

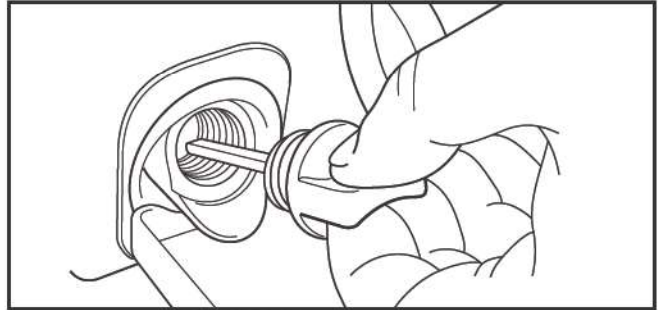

5. Replace and tighten oil fill cap.
6. Reinstall the side maintenance cover and hand tighten the cover screws.

Adding Engine Oil

1. Make sure generator is on a level surface.
2. Repeat steps 2 through 4 to check oil level as described in *Checking Oil Level*.
3. If needed, slowly pour oil into oil fill opening to the point of overflowing at oil fill.
4. Replace and tighten oil fill cap.
5. Reinstall the side maintenance cover and hand tighten the cover screws.

Changing Engine Oil

If you are using your generator under extremely dirty or dusty conditions, or in extremely hot weather, change the oil more often.

⚠ CAUTION Avoid prolonged or repeated skin contact with used motor oil.

- Used motor oil has been shown to cause skin cancer in certain laboratory animals.
- Thoroughly wash exposed areas with soap and water.



KEEP OUT OF REACH OF CHILDREN. DON'T POLLUTE. CONSERVE RESOURCES. RETURN USED OIL TO COLLECTION CENTERS.

Change the oil while the engine is still warm from running, as follows:

1. Make sure generator is on a level surface.
2. Loosen the side maintenance cover screws and remove the side maintenance cover.
3. Clean area around oil fill and remove oil fill cap.
4. Tip your generator to drain oil from oil fill into a suitable container making sure you tip your unit toward the oil filler neck. When crankcase is empty, return generator to upright position.
5. Slowly pour oil (about 20 oz.) into oil fill opening to the point of overflowing at oil fill cap. DO NOT overfill.

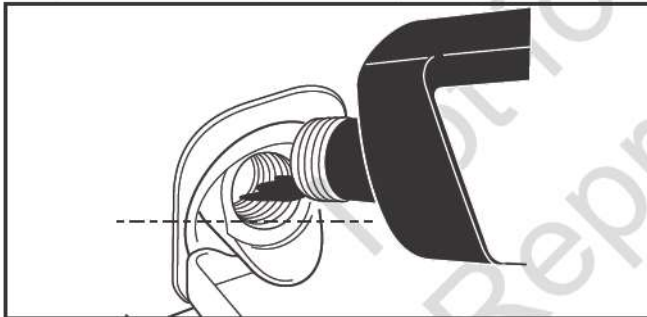

6. Reinstall oil fill cap. Finger tighten cap securely.
7. Wipe up any spilled oil.
8. Reinstall the side maintenance cover and hand tighten the cover screws.

Service Air Cleaner

Your engine will not run properly and may be damaged if you run it with a dirty air cleaner. Service more often if operating under dirty or dusty conditions.

To service the air cleaner, follow these steps:

1. Loosen the side maintenance cover screws and remove the side maintenance cover.
2. Loosen air cleaner cover screw (A) and remove air cleaner cover (B).

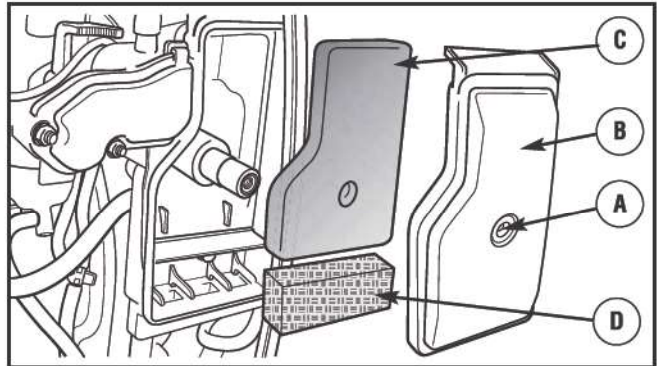

3. Carefully remove foam air cleaner (C) by pulling it out towards you.
4. Carefully remove breather filter (D) by pulling it out towards you.
5. Wash foam air cleaner and breather filter in liquid detergent and water only. Squeeze dry in a clean cloth.
6. SATURATE foam air cleaner in clean engine oil and squeeze in a clean cloth to remove excess oil.
7. Reinstall clean or new foam air cleaner inside base.
8. Reinstall clean or new breather filter inside base.
9. Reinstall the air cleaner cover and tighten screw.
10. Reinstall the side maintenance cover and hand tighten the cover screws.

Service Spark Plug

Changing the spark plug will help your engine to start easier and run better.

1. Push in on tab with screwdriver and remove top maintenance cover.

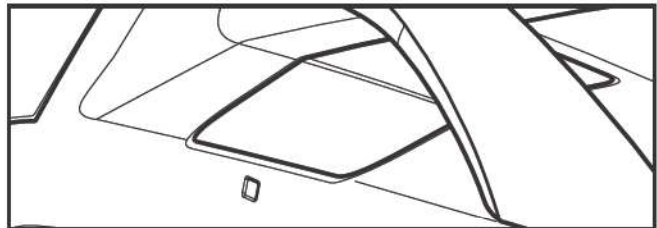

2. Clean area around spark plug and remove spark plug boot.

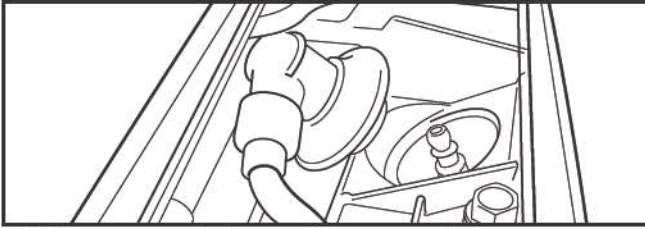

3. Remove spark plug and inspect spark plug.
4. Check electrode gap with wire feeler gauge and reset spark plug gap to recommended gap if necessary (see *Specifications*).

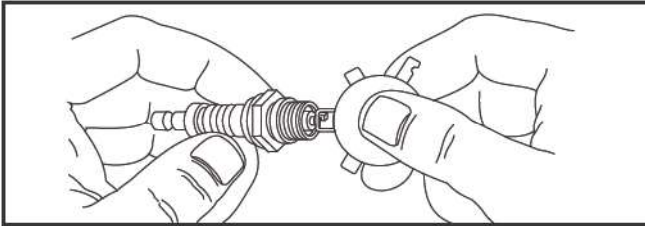

5. Replace spark plug if electrodes are pitted, burned or porcelain is cracked. Use the recommended replacement plug. See *Specifications*.
6. Install spark plug and tighten firmly. Reinstall spark plug boot.
7. Reinstall top maintenance cover.

Inspect Muffler and Spark Arrester

Inspect the muffler for cracks, corrosion, or other damage. Remove the spark arrester, if equipped, and inspect for damage or carbon blockage. If replacement parts are required, make sure to use only original equipment replacement parts.

⚠ WARNING Exhaust heat/gases could ignite combustibles, structures or damage fuel tank causing a fire, resulting in death or serious injury.

Contact with muffler area could cause burns resulting in serious injury.

- DO NOT touch hot parts and AVOID hot exhaust gases.
- Allow equipment to cool before touching.
- Keep at least 5 feet (1.5 m) of clearance on all sides of generator including overhead.
- It is a violation of California Public Resource Code, Section 4442, to use or operate the engine on any forest-covered, brush-covered, or grass-covered land unless the exhaust system is equipped with a spark arrester, as defined in Section 4442, maintained in effective working order. Other states or federal jurisdictions may have similar laws.

Contact the original equipment manufacturer, retailer, or dealer to obtain a spark arrester designed for the exhaust system installed on this engine.

- Replacement parts must be the same and installed in the same position as the original parts.

Clean and inspect the spark arrester as follows:

1. Remove two screws that attaches back bumper to muffler guard. Remove back bumper.

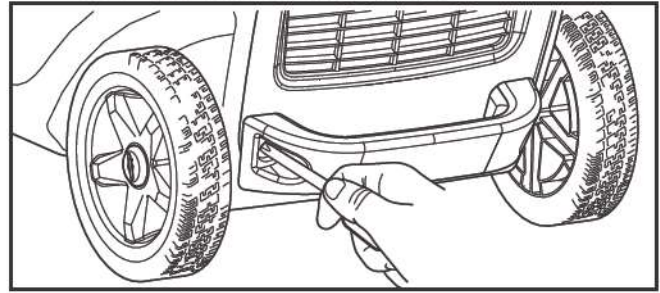

2. To remove muffler guard, remove two top screws that connects guard to generator.

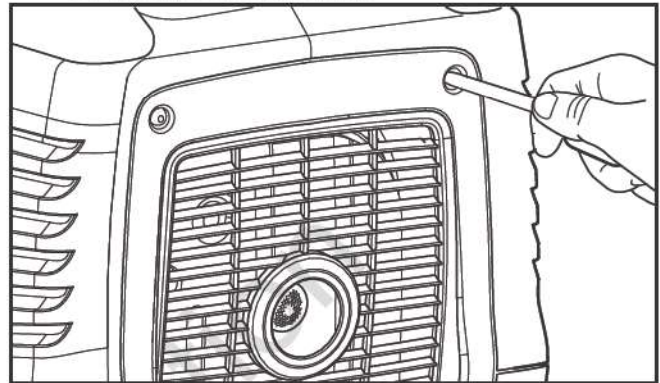

3. Remove screw that attaches spark arrester screen to muffler. Remove spark arrester screen.

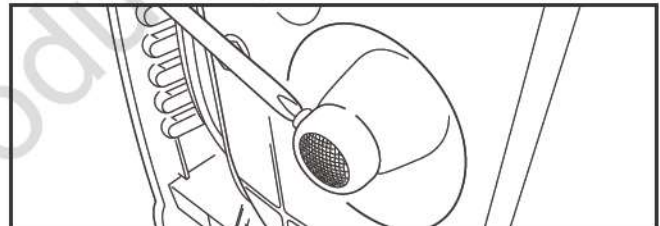

4. Inspect screen and obtain a replacement if torn, perforated or otherwise damaged. DO NOT use a defective screen. If screen is not damaged, clean it with a brush.
5. Reattach screen to muffler. Reattach muffler guard.

Storage

The generator should be started at least once every seven days and allowed to run at least 30 minutes. If this cannot be done and you must store the unit for more than 30 days, use the following guidelines to prepare it for storage.

Generator Storage

- Clean the generator as outlined in *Cleaning*.
- Check that cooling air slots and openings on generator are open and unobstructed.

Long Term Storage Instructions

Fuel can become stale when stored over 30 days. Stale fuel causes acid and gum deposits to form in the fuel system or on essential carburetor parts. To keep fuel fresh, use Briggs & Stratton® Advanced Formula Fuel Treatment & Stabilizer, available wherever Briggs & Stratton genuine service parts are sold.

For engines equipped with a FRESH START® fuel cap, use Briggs & Stratton FRESH START® available in a drip concentrate cartridge.

There is no need to drain gasoline from the engine if a fuel stabilizer is added according to instructions. Run the engine for 2 minutes to circulate the stabilizer throughout the fuel system before storage.

If gasoline in the engine has not been treated with a fuel stabilizer, it must be drained into an approved container. Run the engine until it stops from lack of fuel. The use of a fuel stabilizer in the storage container is recommended to maintain freshness.

 **WARNING** Fuel and its vapors are extremely flammable and explosive which could cause burns, fire or explosion resulting in death or serious injury.

WHEN STORING FUEL OR EQUIPMENT WITH FUEL IN TANK

- Store away from furnaces, stoves, water heaters, clothes dryers or other appliances that have pilot light or other ignition source because they could ignite fuel vapors.

WHEN DRAINING FUEL

- Turn generator engine OFF and let it cool at least 2 minutes before removing fuel cap. Loosen cap slowly to relieve pressure in tank.
- Drain fuel tank outdoors.
- Keep fuel away from sparks, open flames, pilot lights, heat, and other ignition sources.
- Check fuel lines, tank, cap and fittings frequently for cracks or leaks. Replace if necessary.
- DO NOT light a cigarette or smoke.

Change Engine Oil

While engine is still warm, drain oil from crankcase. Refill with recommended grade. See *Changing Engine Oil*.

Other Storage Tips

1. DO NOT store fuel from one season to another unless it has been treated as described in *Long Term Storage Instructions*.
2. Replace fuel container if it starts to rust. Rust and/or dirt in fuel can cause problems if it's used with this unit.
3. DO NOT tip generator up on end and store. Generator must be stored in normal operating position.
4. Cover unit with a suitable protective cover that does not retain moisture.

 **WARNING** Storage covers could cause a fire resulting in death or serious injury.

- DO NOT place a storage cover over a hot generator.
- Let equipment cool for a sufficient time before placing the cover on the equipment.

5. Store generator in clean, dry area.

Troubleshooting

Problem	Cause	Correction
Engine is running, but no AC output is available.	<ol style="list-style-type: none"> 1. Red overload alarm light is on. Generator is overloaded. 2. Green output indicator light not on. Fault in generator. 3. Poor connection or defective cord set. 4. Connected device is bad. 	<ol style="list-style-type: none"> 1. See <i>Don't Overload Generator</i> in <i>Operation</i> section. Press RESET button on control panel. 2. Contact authorized service facility. 3. Check and repair. 4. Connect another device that is in good condition.
Engine runs good at no-load but "bogs down" when loads are connected.	<ol style="list-style-type: none"> 1. Short circuit in a connected load. 2. Engine speed is too slow. 3. Generator is overloaded. 4. Shorted generator circuit. 	<ol style="list-style-type: none"> 1. Disconnect shorted electrical load. 2. Contact authorized service facility. 3. See <i>Don't Overload Generator</i> in <i>Operation</i> section. 4. Contact authorized service facility.
Engine will not start; shuts down when running or starts and runs rough.	<ol style="list-style-type: none"> 1. Engine switch set to OFF (0). 2. Low oil indicator light comes on. Low oil level. 3. Dirty air cleaner. 4. Out of fuel. 5. Stale fuel. 6. Spark plug wire not connected to spark plug. 7. Bad spark plug. 8. Water in fuel. 9. Flooded. 10. Excessively rich fuel mixture. 11. Intake valve stuck open or closed. 12. Engine has lost compression. 	<ol style="list-style-type: none"> 1. Set engine switch to ON (I). 2. Fill crankcase to proper level or place generator on level surface. 3. Clean or replace air cleaner. 4. Fill fuel tank. 5. Drain fuel tank and carburetor; fill with fresh fuel. 6. Connect wire to spark plug. 7. Replace spark plug. 8. Drain fuel tank and carburetor; fill with fresh fuel. 9. Wait 5 minutes and re-crank engine. 10. Contact authorized service facility. 11. Contact authorized service facility. 12. Contact authorized service facility.
Engine lacks power.	<ol style="list-style-type: none"> 1. Load is too high. 2. Dirty air filter. 	<ol style="list-style-type: none"> 1. See <i>Don't Overload Generator</i> in <i>Operation</i> section. 2. Replace air filter.
Engine "hunts" or falters.	Carburetor is running too rich or too lean.	Contact authorized service facility.

Wiring Diagram

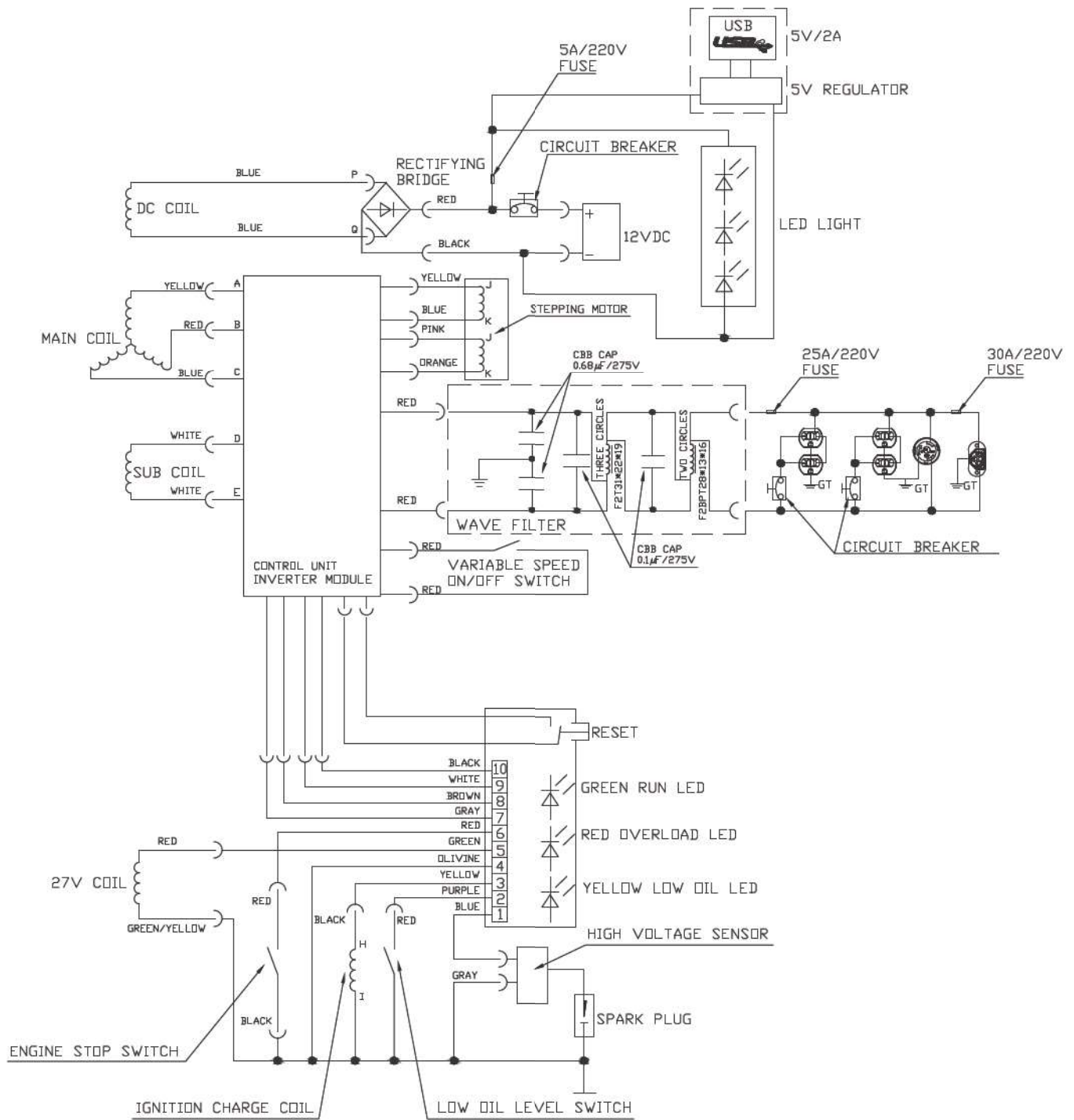

BRIGGS & STRATTON POWER PRODUCTS GROUP, LLC PORTABLE GENERATOR OWNER WARRANTY POLICY

Effective September 1, 2012; replaces all undated Warranties and all Warranties dated before September 1, 2012.

LIMITED WARRANTY

Briggs & Stratton warrants that, during the warranty period specified below, it will repair or replace, free of charge, any part that is defective in material or workmanship or both. Transportation charges on product submitted for repair or replacement under this warranty must be borne by purchaser. This warranty is effective for and is subject to the time periods and conditions stated below. For warranty service, find the nearest Authorized Service Dealer in our dealer locator map at BRIGGSandSTRATTON.com. The purchaser must contact the Authorized Service Dealer, and then make the product available to the Authorized Service Dealer for inspection and testing.

There is no other express warranty. Implied warranties, including those of merchantability and fitness for a particular purpose, are limited to one year from purchase, or to the extent permitted by law. All other implied warranties are excluded. Liability for incidental or consequential damages are excluded to the extent exclusion is permitted by law. Some states or countries do not allow limitations on how long an implied warranty lasts, and some states or countries do not allow the exclusion or limitation of incidental or consequential damages, so the above limitation and exclusion may not apply to you. This warranty gives you specific legal rights and you may also have other rights which vary from state to state or country to country.**

WARRANTY PERIOD

Consumer Use	2 years*
Commercial Use	1 year

*Second year parts only

** In Australia - Our goods come with guarantees that cannot be excluded under the Australian Consumer Law. You are entitled to a replacement or refund for a major failure and for compensation for any other reasonably foreseeable loss or damage. You are also entitled to have the goods repaired or replaced if the goods fail to be of acceptable quality and the failure does not amount to a major failure. For warranty service, find the nearest Authorized Service Dealer in our dealer locator map at BRIGGSandSTRATTON.COM, or by calling 1300 274 447, or by emailing or writing to salesenquires@briggsandstratton.com.au, Briggs & Stratton Australia Pty Ltd, 1 Moorebank Avenue, NSW, Australia, 2170.

The warranty period begins on the date of purchase by the first retail end user, and continues for the period of time stated above. "Consumer Use" means personal residential household use by a retail consumer. "Commercial Use" means all other uses, including use for commercial, income producing or rental purposes. Once equipment has experienced commercial use, it shall thereafter be considered as commercial use for purposes of this warranty. Equipment used for prime power in place of utility are not applicable to this warranty.

NO WARRANTY REGISTRATION IS NECESSARY TO OBTAIN WARRANTY ON BRIGGS & STRATTON PRODUCTS. SAVE YOUR PROOF OF PURCHASE RECEIPT. IF YOU DO NOT PROVIDE PROOF OF THE INITIAL PURCHASE DATE AT THE TIME WARRANTY SERVICE IS REQUESTED, THE MANUFACTURING DATE OF THE PRODUCT WILL BE USED TO DETERMINE THE WARRANTY PERIOD.

ABOUT YOUR WARRANTY

We welcome warranty repair and apologize to you for being inconvenienced. Any Authorized Service Dealer may perform warranty repairs. Most warranty repairs are handled routinely, but sometimes requests for warranty service may not be appropriate. For example, warranty service would not apply if equipment damage occurred because of misuse, lack of routine maintenance, shipping, handling, warehousing or improper installation. Similarly, the warranty is void if the manufacturing date or the serial number on the portable generator has been removed or the equipment has been altered or modified. During the warranty period, the Authorized Service Dealer, at its option, will repair or replace any part that, upon examination, is found to be defective under normal use and service. This warranty will not cover the following repairs and equipment:

- **Normal Wear:** Outdoor Power Equipment, like all mechanical devices, needs periodic parts and service to perform well. This warranty does not cover repair when normal use has exhausted the life of a part or the equipment.
- **Installation and Maintenance:** This warranty does not apply to equipment or parts that have been subjected to improper or unauthorized installation or alteration and modification, misuse, negligence, accident, overloading, overspeeding, improper maintenance, repair or storage so as, in our judgment, to adversely affect its performance and reliability. This warranty also does not cover normal maintenance such as air filters, adjustments, fuel system cleaning and obstruction (due to chemical, dirt, carbon, lime, and so forth).
- **Other Exclusions:** This warranty excludes wear items such as o-rings, filters, etc., or malfunctions resulting from accidents, abuse, modifications, alterations, or improper servicing or freezing or chemical deterioration. Accessory parts such as starting batteries, generator adapter cord sets and storage covers are excluded from the product warranty. This warranty excludes used, reconditioned, and demonstration equipment, equipment used for prime power in place of utility power, equipment used in life support applications, and failures due to acts of God and other force majeure events beyond the manufacturers control. 198189E, Rev. D, 09/10/2012

BRIGGS & STRATTON POWER PRODUCTS GROUP, LLC
MILWAUKEE, WI, USA

Not for
Reproduction

Not for
Reproduction

Not for
Reproduction



Inverter Generator

Product Specifications

Starting Wattage	3,000 Watts
Wattage*	2,600 Watts
Load Current:		
at 120 Volts AC21.6 Amps
at 12 Volts DC5 Amps
Rated Frequency60 Hertz
Phase	Single Phase
Displacement	10.44 cu. in. (171 cc)
Spark Plug Gap	0.023-0.027 in. (0.6-0.7 mm)
Fuel Capacity	1.5 U.S. gallon (5.7 L)
Oil Capacity20 Ounces (0.6 L)

Common Service Parts

Foam Air Cleaner311388GS
Breather Filter311389GS
Resistor Spark PlugNGK CR7HSA
Engine Oil Bottle100005 or 100028
Synthetic Oil Bottle100074
Fuel Stabilizer100120 or 100117

Power Ratings: The gross power rating for individual gasoline engine models is labeled in accordance with SAE (Society of Automotive Engineers) code J1940 Small Engine Power & Torque Rating Procedure, and is rated in accordance with SAE J1995. Torque values are derived at 2600 RPM for those engines with "rpm" called out on the label and 3060 RPM for all others; horsepower values are derived at 3600 RPM. The gross power curves can be viewed at www.BRIGGSandSTRATTON.COM. Net power values are taken with exhaust and air cleaner installed whereas gross power values are collected without these attachments. Actual gross engine power will be higher than net engine power and is affected by, among other things, ambient operating conditions and engine-to-engine variability. Given the wide array of products on which engines are placed, the gasoline engine may not develop the rated gross power when used in a given piece of power equipment. This difference is due to a variety of factors including, but not limited to, the variety of engine components (air cleaner, exhaust, charging, cooling, carburetor, fuel pump, etc.), application limitations, ambient operating conditions (temperature, humidity, altitude), and engine-to engine variability. Due to manufacturing and capacity limitations, Briggs & Stratton may substitute an engine of higher rated power for this engine.

* This generator is certified in accordance with CSA (Canadian Standards Association) standard C22.2 No. 100-04 (motors and generators) and rated in accordance with PGMA (Portable Generator Manufacturers' Association) standard PGMA G200 (Standard for Testing and Validating Performance of Portable Generators).

Briggs & Stratton Power Products Group, LLC
P.O. Box 702
Milwaukee, Wisconsin, 53201-0702 U.S.A.